

DIMENSIONAL CHARACTERISTICS
FOR
WILWOOD HUBS, BEARINGS AND SEALS
APPROVED FOR EXTERNAL DISTRIBUTION

PART NUMBER GROUPS
270-xxxxx, 370-xxxxx, 380-xxxxx

**DISC BRAKES SHOULD ONLY BE INSTALLED BY SOMEONE
EXPERIENCED AND COMPETENT IN THE INSTALLATION
AND MAINTENANCE OF DISC BRAKES**
READ ALL WARNINGS

WARNING

IT IS THE RESPONSIBILITY OF THE PERSON INSTALLING ANY BRAKE COMPONENT OR KIT TO DETERMINE THE SUITABILITY OF THE COMPONENT OR KIT FOR THAT PARTICULAR APPLICATION. IF YOU ARE NOT SURE HOW TO SAFELY USE THIS BRAKE COMPONENT OR KIT, YOU SHOULD NOT INSTALL OR USE IT. DO NOT ASSUME ANYTHING. IMPROPERLY INSTALLED OR MAINTAINED BRAKES ARE DANGEROUS. IF YOU ARE NOT SURE, GET HELP OR RETURN THE PRODUCT. YOU MAY OBTAIN ADDITIONAL INFORMATION AND TECHNICAL SUPPORT BY CALLING WILWOOD AT (805) 388-1188, OR VISIT OUR WEB SITE AT WWW.WILWOOD.COM. USE OF WILWOOD TECHNICAL SUPPORT DOES NOT GUARANTEE PROPER INSTALLATION. **YOU**, OR THE PERSON WHO DOES THE INSTALLATION MUST KNOW HOW TO PROPERLY USE THIS PRODUCT. IT IS NOT POSSIBLE OVER THE PHONE TO UNDERSTAND OR FORESEE ALL THE ISSUES THAT MIGHT ARISE IN YOUR INSTALLATION.

RACING EQUIPMENT AND BRAKES MUST BE MAINTAINED AND SHOULD BE CHECKED REGULARLY FOR FATIGUE, DAMAGE, AND WEAR.



WARNING

DO NOT OPERATE ANY VEHICLE ON UNTESTED BRAKES!
SEE MINIMUM TEST PROCEDURE WITHIN

ALWAYS UTILIZE SAFETY RESTRAINT SYSTEMS AND ALL OTHER AVAILABLE SAFETY EQUIPMENT WHILE OPERATING THE VEHICLE

IMPORTANT • READ THE DISCLAIMER OF WARRANTY INCLUDED IN THE KIT

NOTE: Some cleaners may stain or remove the finish on brake system components. Test the cleaner on a hidden portion of the component before general use.

Wilwood Hubs, Bearing Dimensional Characteristics

WARNING
 INSTALLATION OF THIS COMPONENT SHOULD ONLY BE PERFORMED BY PERSONS EXPERIENCED IN THE INSTALLATION AND PROPER OPERATION OF DISC BRAKE SYSTEMS.

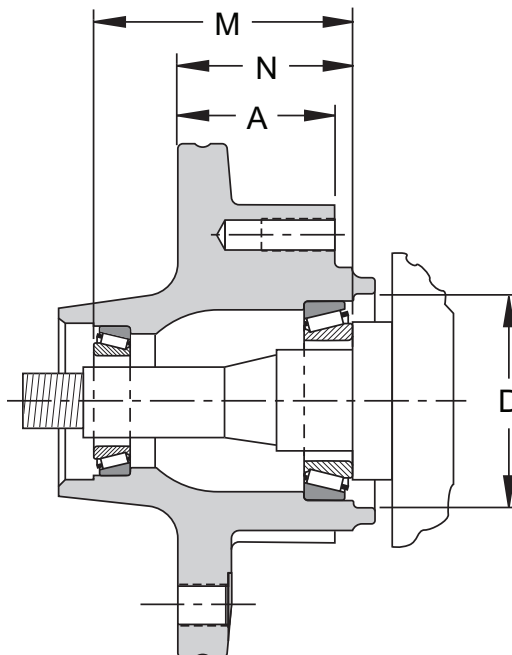

NOTE
 SPECIFIC PARTS MAY VARY FROM DIAGRAM

Figure 1. Typical Hub/Bearing Configuration

HUB PART NUMBER	DESCRIPTION VEHICLE TYPE	WHEEL BC	ROTOR OFFSET	DIM A	DIM D	DIM M	DIM N	WILWOOD INNER RACE PART #	WILWOOD OUTER RACE PART #	WILWOOD INNER BEARING PART #	WILWOOD OUTER BEARING PART #	INNER BEARING SHAFT OD	OUTER BEARING SHAFT OD
270-3204	87-93 MUST 4 LUG	A	H	N/A	2.574	2.93	1.54	370-2571	370-0881	370-2609	370-0882	1.3750	0.8656
270-3268	87-93 MUST 5 LUG	B	H	N/A	2.574	2.93	1.54	370-2571	370-0881	370-2609	370-0882	1.3750	0.8656
270-6989	PINTO/MUST BB	C	H	N/A	2.495	3.15	2.06	370-0883	370-0881	370-0884	370-0882	1.3775	0.8656
270-7037	64-72 NOVA BB	C	H	N/A	2.495	3.15	2.37	370-0878	370-0876	370-0879	370-0877	1.2500	0.7500
270-7274	67-74 NOVA	C	V	1.795	2.495	3.15	2.39	370-0878	370-0876	370-0879	370-0877	1.2500	0.7500
270-7275	67-74 NOVA	C	S	1.850	2.495	3.15	2.06	370-0878	370-0876	370-0879	370-0877	1.2500	0.7500
270-7276	PINTO/MUST	C	V	1.795	2.495	3.15	2.39	370-0883	370-0881	370-0884	370-0882	1.3775	0.8656
270-7277	PINTO/MUST	C	S	1.850	2.495	3.15	2.06	370-0883	370-0881	370-0884	370-0882	1.3775	0.8656
270-7279	37-48 FORD	C	V	1.940	2.502	4.12	2.41	370-1560	370-0876	370-1561	370-0877	1.1895	0.7500
270-7281	37-48 FORD	C	S	2.375	2.502	4.12	2.41	370-1560	370-0876	370-1561	370-0877	1.1895	0.7500
270-7283	55-57 CHEV	C	V	1.795	2.495	3.07	2.41	370-0878	370-0876	370-0879	370-0877	1.2500	0.7500
270-7285	87-93 MUST	C	S	1.882	2.574	2.93	2.12	370-2571	370-0881	370-2609	370-0882	1.3750	0.8656
270-7287	GRANADA	C	V	1.966	2.495	3.02	1.90	370-0883	370-0881	370-0884	370-0882	1.3775	0.8656
270-7309	80-87 G-BODY	C	V	1.795	2.495	3.15	2.39	370-0878	370-0881	370-0879	370-0933	1.2500	0.8437
270-7309-P	80-87 G-BODY	C	V	1.795	2.495	3.15	2.39	370-0878	370-0881	370-0879	370-0933	1.2500	0.8437
270-7310	80-87 G-BODY	C	S	1.850	2.495	3.15	2.06	370-0878	370-0881	370-0879	370-0933	1.2500	0.8437
270-7311	VEGA	C	S	1.850	2.495	3.38	2.16	370-0878	370-1238	370-0879	370-1239	1.2500	0.6875
270-7466	GRANADA BB	C	H	N/A	2.495	3.02	1.72	370-0883	370-0881	370-0884	370-0882	1.3775	0.8656
270-7631	55-57 CHEVY BB	C	H	N/A	2.495	2.97	1.52	370-0878	370-0876	370-0879	370-0877	1.2500	0.7500
270-7680	87-93 MUST	C	V	1.752	2.573	2.93	2.36	370-2571	370-0881	370-2609	370-0882	1.3750	0.8656
270-8767	65-72 A BODY 10"	D	V	1.795	2.332	2.97	2.41	370-0878	370-0876	370-0879	370-0877	1.2500	0.7500
270-8769	65-72 A BODY 10"	D	S	1.850	2.332	2.97	2.09	370-0878	370-0876	370-0879	370-0877	1.2500	0.7500
270-8771	62-72 A BODY 9"	D	V	1.800	2.433	2.95	2.30	370-3146	370-1238	370-3147	370-1239	1.0625	0.6875
270-8773	62-72 A BODY 9"	D	S	2.080	2.433	2.95	2.07	370-3146	370-1238	370-3147	370-1239	1.0625	0.6875
270-8775	73-76 A BODY DSC	D	V	1.906	2.619	3.73	2.31	370-0883	370-0876	370-0884	370-0877	1.3775	0.7500
270-8777	73-76 A BODY DSC	D	S	1.956	2.619	3.70	2.02	370-0883	370-0876	370-0884	370-0877	1.3775	0.7500

WHEEL BC STUD HOLE SIZE
 A = 4 x 4.25 1/2-20
 B = 5 x 4.50 1/2-20
 C = 5 x 4.50 & 4.75 1/2-20

WHEEL BC STUD HOLE SIZE
 D = 5 x 4.00 & 4.50 1/2-20
 E = 5 x 5.00 1/2-20

H = FOR USE WITH HAT
 S = SOLID, .35" THICK (USES DIRECT MOUNT SOLID ROTOR, OR ROTOR ADAPTER: 300-3307)
 V = VENTED, .81" THICK (USES ROTOR ADAPTER: 300-3307 OR 300-3099)

Wilwood Hubs, Bearing Dimensional Characteristics (Continued)

HUB PART NUMBER	DESCRIPTION VEHICLE TYPE	WHEEL BC	ROTOR OFFSET	DIM A	DIM D	DIM M	DIM N	WILWOOD INNER RACE PART #	WILWOOD OUTER RACE PART #	WILWOOD INNER BEARING PART #	WILWOOD OUTER BEARING PART #	INNER BEARING SHAFT OD	OUTER BEARING SHAFT OD
270-8779	62-72 B/E BODY	D	V	1.906	2.332	3.74	2.31	370-0878	370-0876	370-0879	370-0877	1.2500	0.7500
270-8781	62-72 B/E BODY	D	S	1.926	2.332	3.70	2.02	370-0878	370-0876	370-0879	370-0877	1.2500	0.7500
270-9320	70-73 MUSTANG BB	C	H	N/A	2.495	3.13	1.69	370-0883	370-0881	370-0884	370-0882	1.3775	0.8656
270-9486	PINTO/MUST BB	C	H	N/A	2.495	3.15	1.63	370-0883	370-0881	370-0884	370-0882	1.3775	0.8656
270-9502	68-69 MUSTANG BB	C	H	N/A	2.495	3.13	1.69	370-0883	370-0881	370-0884	370-0882	1.3775	0.8656
270-10044	WWE PRO SPINDLE	C	V	1.750	2.495	3.15	1.74	370-0883	370-0881	370-0884	370-0882	1.3775	0.8656
270-10237	LARGE GM	C	H	N/A	2.495	3.21	1.97	370-0878	370-0876	370-0879	370-0877	1.2500	0.7500
270-10438	CAMARO 70-78	C	V	1.584	2.495	3.15	1.64	370-0878	370-0876	370-0879	370-0877	1.2500	0.7500
270-10439	CAMARO 79-81	C	V	1.584	2.495	3.15	1.64	370-0878	370-0881	370-0879	370-0933	1.2500	0.8437
270-10442	PINTO/MUST	C	V	1.584	2.495	3.15	1.64	370-0883	370-0881	370-0884	370-0882	1.3775	0.8656
270-10487	CAMARO 70-78	C	H	N/A	2.495	3.15	1.63	370-0878	370-0876	370-0879	370-0877	1.2500	0.7500
270-10494	CAMARO 79-81	C	H	N/A	2.495	3.15	1.63	370-0878	370-0881	370-0879	370-0933	1.2500	0.8437
270-10658	PINTO/MUST BB	E	H	N/A	2.495	3.15	2.06	370-0883	370-0881	370-0884	370-0882	1.3775	0.8656
270-10660	PINTO/MUST	E	V	1.795	2.495	3.15	2.39	370-0883	370-0881	370-0884	370-0882	1.3775	0.8656
270-10812	62-72 B/E BODY	C	H	N/A	2.332	3.71	1.89	370-0878	370-0876	370-0879	370-0877	1.2500	0.7500
270-11032	55-57 CHEVY	C	V	1.150	2.495	2.97	1.83	370-0878	370-0876	370-0879	370-0877	1.2500	0.7500
270-11043	80-87 G-BODY	C	V	1.724	2.495	3.15	1.52	370-0878	370-0881	370-0879	370-0933	1.2500	0.8437
270-11048	CAMARO 79-81	C	V	2.135	2.495	3.15	1.84	370-0878	370-0881	370-0879	370-0933	1.2500	0.8437
270-11050	CAMARO 70-78	C	V	2.135	2.495	3.15	1.84	370-0878	370-0876	370-0879	370-0877	1.2500	0.7500
270-11058	MUSTANG 65-69	C	V	0.913	2.495	3.15	1.76	370-0878	370-0876	370-0879	370-0877	1.2500	0.7500
270-11070	MUSTANG 70-73	C	V	0.913	2.495	3.15	1.76	370-0883	370-0881	370-0884	370-0882	1.3775	0.8656
270-11252	PINTO/MUST	C	V	1.720	2.495	3.14	1.64	370-0883	370-0881	370-0884	370-0882	1.3775	0.8656
270-11256	87-93 MUSTANG	C	V	1.146	2.573	2.93	1.87	370-2571	370-0881	370-2609	370-0882	1.3750	0.8656
270-11516	62-72 B/E BODY	D	V	1.720	0.570	3.74	2.19	370-0878	370-0876	370-0879	370-0877	1.2500	0.7500
270-11527	62-72 A BODY - 9"	D	V	1.170	0.570	2.95	1.96	370-11554	370-1238	370-11555	370-1239	1.0625	0.6875
270-11533	73-76 A BODY DISC	C	H	N/A	0.570	3.73	2.06	370-0883	370-0876	370-0884	370-0877	1.3775	0.7500
270-11539	65-72 A BODY - 10"	D	V	1.145	0.570	2.97	1.95	370-0878	370-0876	370-0879	370-0877	1.2500	0.7500

WHEEL BC STUD HOLE SIZE

A = 4 x 4.25 1/2-20
 B = 5 x 4.50 1/2-20
 C = 5 x 4.50 & 4.75 1/2-20

WHEEL BC STUD HOLE SIZE

D = 5 x 4.00 & 4.50 1/2-20
 E = 5 x 5.00 1/2-20

H = FOR USE WITH HAT

S = SOLID, .35" THICK (USES DIRECT MOUNT SOLID ROTOR, OR ROTOR ADAPTER: 300-3307)
 V = VENTED, .81" THICK (USES ROTOR ADAPTER: 300-3307 OR 300-3099)

Important Notice - Please Read

Bearing and seal information is for reference only. Do not mix cup and cone bearings between bearing sets, as bearing diameter, roller angle or width may be incompatible with cup (race).

Bearings, Dimensional Characteristics

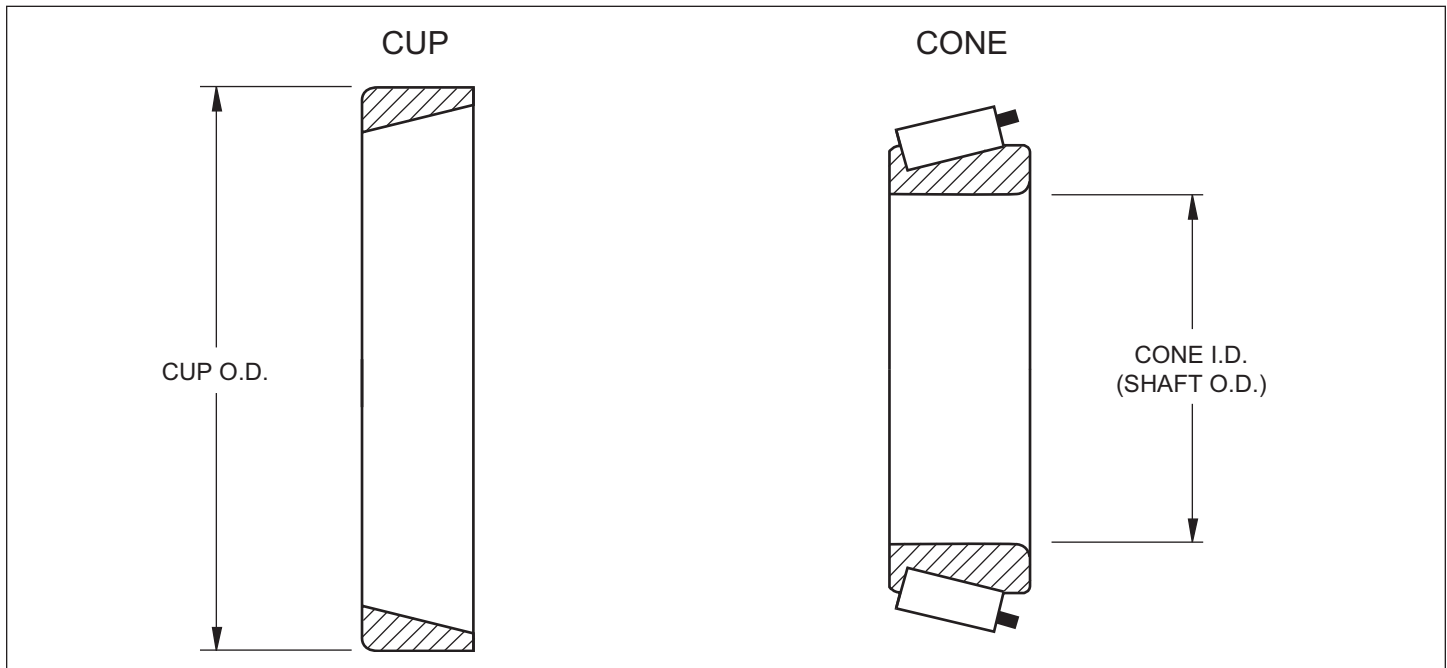

Figure 2. Typical Bearing Configurations

Wilwood Part No.	Bearing Style	Cup O.D.	Cone I.D. Shaft O.D.
370-0876	Cup	1.7810	
370-0877	Cone		0.7500
370-0878	Cup	2.3280	
370-0879	Cone		1.2500
370-0881	Cup	1.7810	
370-0882	Cone		0.8656
370-0883	Cup	2.3280	
370-0884	Cone		1.3775
370-0933	Cone		0.8437
370-1238	Cup	1.5700	
370-1239	Cone		0.6875
370-1560	Cup	2.5000	
370-1561	Cone		1.1895
370-2571	Cup	2.5625	
370-2609	Cone		1.3750
370-3146	Cup	1.9800	
370-3147	Cone		1.0625
370-9542	Cone		0.8437
370-9245	Cup	1.9687	
N/A	Cup	2.3612	
N/A	Cup	1.8110	
370-11554	Cup	2.2500	
370-11555	Cone		1.0625

Seals, Dimensional Characteristics

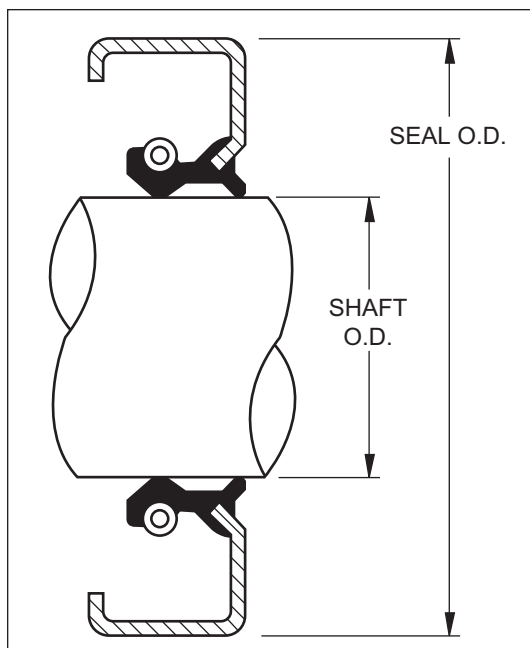

Figure 3. Typical Seal Configuration

Wilwood Part No.	Seal O.D.	Shaft O.D.
380-0880	2.506	1.500
380-0885	2.505	1.940
380-0888	2.441	1.750
380-0927	2.506	1.750
380-0928	2.506	1.875
380-1165	2.506	2.000
380-1562	2.506	1.562
380-2572	2.578	1.938
380-3232	2.340	1.730
380-3446	2.627	1.937
380-3687	2.441	1.500
380-9453	2.566	2.000

Brake Testing

**WARNING • DO NOT DRIVE ON UNTESTED BRAKES
BRAKES MUST BE TESTED AFTER INSTALLATION OR MAINTENANCE
MINIMUM TEST PROCEDURE**

- Make sure pedal is firm: Hold firm pressure on pedal for several minutes, it should remain in position without sinking. If pedal sinks toward floor, check system for fluid leaks. DO NOT drive vehicle if pedal does not stay firm or can be pushed to the floor with normal pressure.
- At very low speed (2-5 mph) apply brakes hard several times while turning steering from full left to full right, repeat several times. Remove the wheels and check that components are not touching, rubbing, or leaking.
- Carefully examine all brake components, brake lines, and fittings for leaks and interference.
- Make sure there is no interference with wheels or suspension components.
- Drive vehicle at low speed (15-20 mph) making moderate and hard stops. Brakes should feel normal and positive. Again check for leaks and interference.
- Always test vehicle in a safe place where there is no danger to (or from) other people or vehicles.
- Always wear seat belts and make use of all safety equipment.