

IMPORTANT!

If “clocking” of the starter block is required, it is critical that the infi-CLOCK ring be tightened correctly.

Note: The starter comes pre-clocked for most applications.



Clocking steps:

1. Loosen the two bolts that retain the infi-CLOCK ring using a 3 mm hex key.
2. Temporarily mount the starter to the engine.
3. Rotate the starter body to the preferred position and make a reference mark from the starter block to the starter body.
4. Remove the starter.
5. Rotate the block into position and tighten the two ring bolts. The bolts must be tightened evenly. While holding the ring parallel to the block, lightly snug each bolt. Evenly tighten the bolts in an alternating pattern. Torque to 50 in/lbs. Inspect the ring again to be certain it is parallel to the block.
6. Reinstall the starter to the engine.

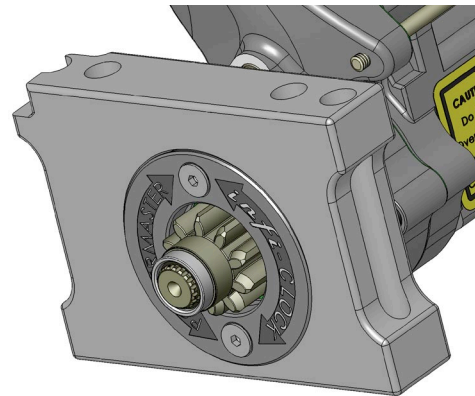

Using Blue Loctite® on the two ring bolts is recommended.

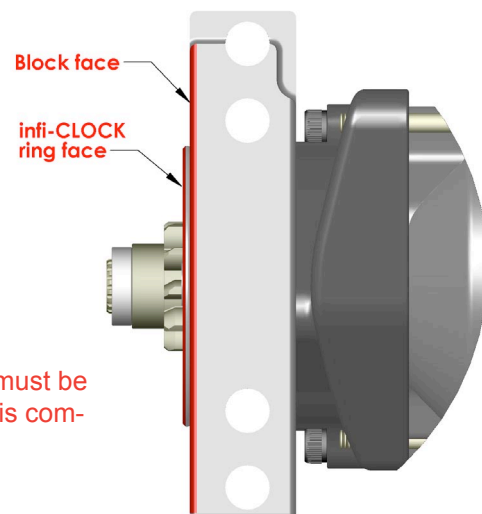

*Ring and block face must be parallel after clocking is complete.